

MPL-F-266/0.1~5uJ/1~20mW



### LD PUMPED ALL-SOLID-STATE UV LASER

All solid state 266 nm UV laser is made features of ultra compact, long lifetime, cost -effectiveness and easy operating, which is widely used in UV curing, micro-electronics, CD carving, laser medical treatment, scientific experiment, etc.



### SPECIFICATIONS

Central wavelength (nm)	266±1	
Output average power (mW)	1~20	
Transverse mode	Near TEM <sub>00</sub>	
Operating mode	Frequency conversion of Q-switched pulsed laser	
Single pulse energy (μJ)	0.1~5	
Pulse duration (ns)	~5	
Peak power(W)	20~1000	
Rep. rate (kHz)	FIXED	Setting up one fixed rep. rate internal between 1kHz-4kHz with stable pulse energy, pulse duration and pulse period.
	EXT TRIG	1kHz-4kHz by external trigger with stable pulse energy, pulse duration and pulse period.
	QCW	QCW state with one rep. rate between 5kHz-7kHz.
Average power (mW)	Average power (mW) = Single pulse energy (μJ) * Rep. rate (kHz)	
Ave power stability (over 4 hours)	<5%, <10%	
Warm-up time (minutes)	<10	
M <sup>2</sup> factor	<1.5	
Spectral purity	>99%	
Beam parameters	Elliptical (4:1), Beam spot ~2mm	
Polarization ratio	>100:1	
Beam height from base plate (mm)	45	
Operating temperature (°C)	10~35	
Power supply (90-264VAC)	PSU-H-FDA	
Expected lifetime (hours)	5000	
Warranty period	1 year	
Remarks	Please Note: because of the Walk-off effect of Nonlinear crystals, the beam quality of UV laser is not so good as that of 1064/532nm laser.	

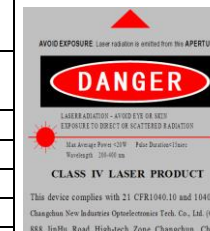

MPL-F-266 (with 266/532/1064 nm laser included)	MPL-F-266 (With 266 nm laser emitting)	PSU-H-FDA	UV prism
<p>211 (L)×88(W)×74(H) mm<sup>3</sup>, 1.6 kg</p>	<p>245.5(L)×88(W)×74(H) mm<sup>3</sup>, 2.0 kg</p>	<p>238 (L) ×145 (W) ×104 (H) mm<sup>3</sup>, 2.3 kg</p>	