

High Power Fiber-Coupled CW Module

K81D07M-12.0W

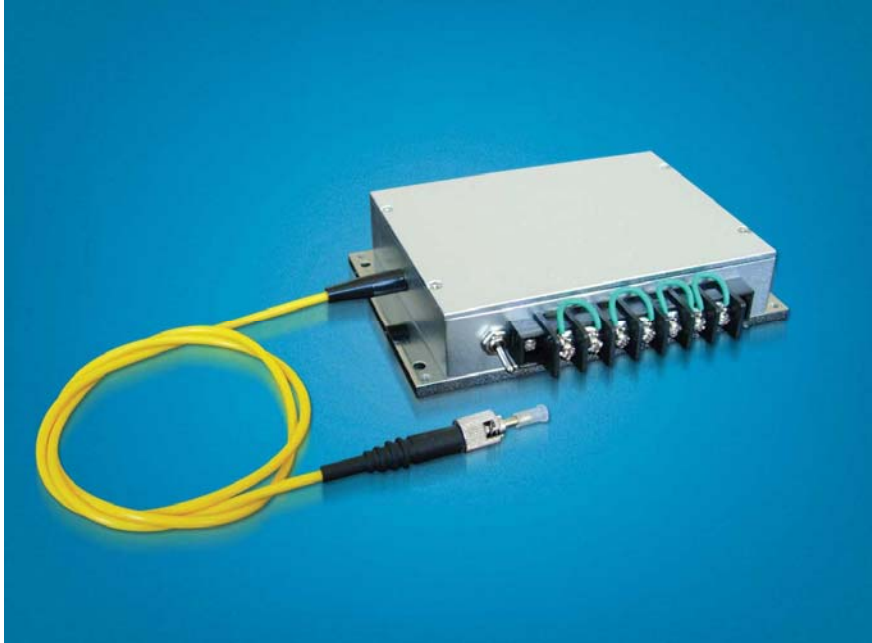

Key Features:

- ◆ 12W output power
- ◆ 360 μ m fiber core diameter
- ◆ 0.22NA
- ◆ 808nm wavelength

Applications:

- ◆ Laser pumping
- ◆ Medical use
- ◆ Printing
- ◆ Heating
- ◆ Material processing
- ◆ Marking

BWT Beijing's High Power Diode Laser Modules are manufactured by adopting specialized fiber-coupling techniques, resulting in volume products with a high efficiency, stability and superior beam quality. The products are achieved by transforming the asymmetric radiation from the laser diode chip into an output fiber with small core diameter by using special micro optics. Inspecting and burn-in procedures in every aspect come to a result to guarantee each product with the reliability, stability and long lifetime.

Our research staffs are constantly improving and innovating the processing technology in the producing process, based on the professional knowledge and experience accumulated in long-terms. We are also continuously developing new products to meet customers' specific needs.

At BWT Beijing, to provide high quality products with reasonable price is our always goal.

High Power Fiber-Coupled CW Module

K81D07M-12.0W

Specifications (25°C)		Symbol	Unit	K81D07M-12.0W
Optical data	CW-output power ¹	P_O	W	12
	Center wavelength	λ_c	nm	808
	Tolerance of λ	-	nm	$\pm 3, \pm 5, \pm 10$
	Temperature drift of λ	-	nm/°C	~0.3
Fiber data ²	Fiber core diameter	W_c	μm	360
	Numerical aperture	NA	-	0.22
	Fiber connector	-	-	FC, ST, SMA-905
Electrical data	Operation current	I_{op}	A	2.5
	Threshold current	I_{th}	A	0.40±0.04
	Conversion efficiency ³	η	%	40
	Slope efficiency ⁴	η_D	W/A	6
	Operation voltage	V_{op}	V	~12.0
	Reverse voltage	V_{re}	V	12
PD data ⁵	Current	I_{mo}	mA	2.4±0.5
Aiming beam data ⁶	Output power	P_a	mW	>2
	Wavelength	λ_a	nm	650±10
Other specifications	Operation temperature	T_{op}	°C	10~30
	Storage temperature	T_{st}	°C	-20~80
	Expected lifetime	MTBF	h	>10,000
	Dimensions ⁷ (fiber and connector not included)	-	mm	~123×80×23
	Weight	-	g	~600

1. Contains 6 of >2W 808nm modules with PD inside. All 808nm LDs are in serial connected.

2. Other fibers available for OEM applications. Contact BWT Beijing.

3. $\eta = P_O / (I_{op} V_{op})$.

4. $\eta_D = P_O / (I_{op} - I_{th})$.

5 All PDs are in parallel connected..

6. Customer can choose adding a 650nm 2mW laser diode for aiming beam, the specification is:

(1) Supply voltage 5VDC, current <50mA.

(2) In the temperature range of 0-50°C, optical power variation <20%.

7. Smaller package is available.

High Power Fiber-Coupled CW Module

K81D07M-12.0W

LD Characteristics

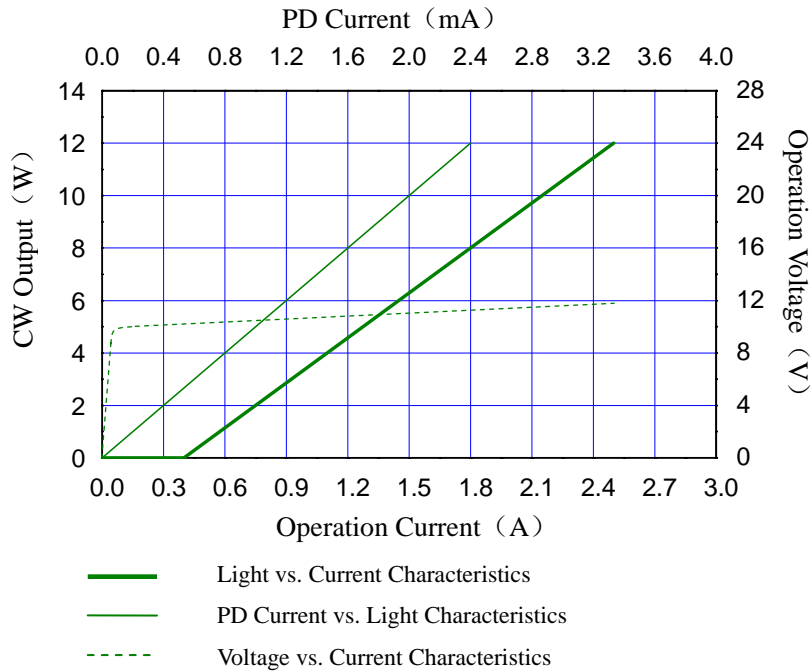

Typ. spectrum (T=25°C)

Typ. spectrum of 808nm diode laser modules

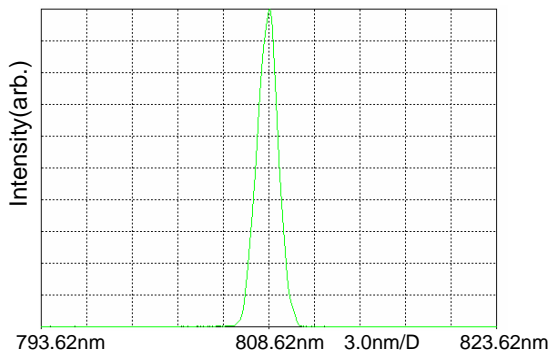

Typ. spectrum of 650nm diode laser modules

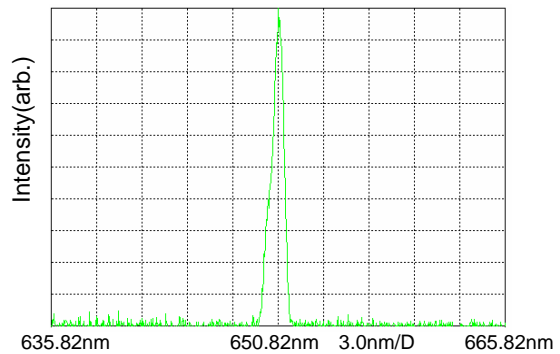

High Power Fiber-Coupled CW Module

K81D07M-12.0W

Package Dimensions (mm)

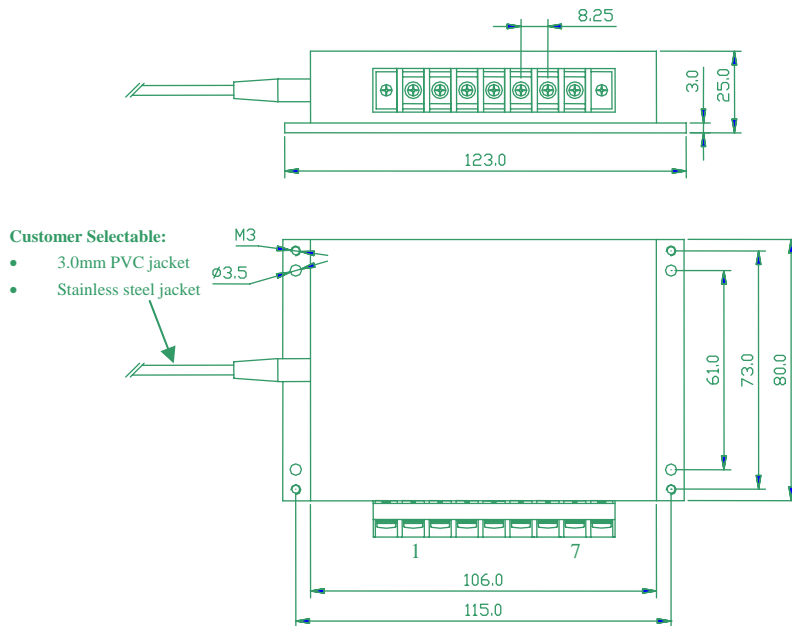

Pin	Function
1	Laser Anode (+)
2	Laser Cathode (-)
3	PD (N)
4	PD (P)
5	Aiming Beam LD (+) (Input 5V +) *
6	Aiming Beam LD (-) (Input 5V -) *
7	Aiming Beam Control *

* Aiming beam will be at CW condition when connecting Pin 5 and Pin 7.

OPERATING NOTES

- Avoid eye exposure to direct or scattered radiation when the device is in operation.
- ESD precautions must be taken when handling unit.
- Using constant power supplies to guarantee the component works under the limits of its maximum peak optical power.
- The laser diode must be used under the specifications.
- Unit requires a condition to spread the heat as well as possible.
- Keep the fiber end clean before use. Fiber is not allowed to be curved so much. The diameter of curvature should be 300 times greater than fiber diameter.
- Environment temperature is 10°C--30°C.
- Storage temperature is -20°C--80°C, short circuit store.



VISIBLE AND/OR INVISIBLE LASER RADIATION
AVOID EYE OR SKIN EXPOSURE TO DIRECTOR
SCATTERED RADIATION
MAXIMUM OUTPUT IS DEPENDANT UPON AND LESS THAN
INPUT RADIATION EMITTED WAVELENGTH DEPENDS UPON
FILTER SETTING
CLASS IV LASER PRODUCT



Information and specifications contained herein are deemed to be reliable and accurate. BWT Beijing reserves the right to change, alter or modify the design and specifications of these products at any time with out notice.