

## 660nm~690nm HHL Window Package LD Module

K66S09W-1.00W    K67S09W-1.00W    K68S09W-1.00W    K69S09W-1.00W

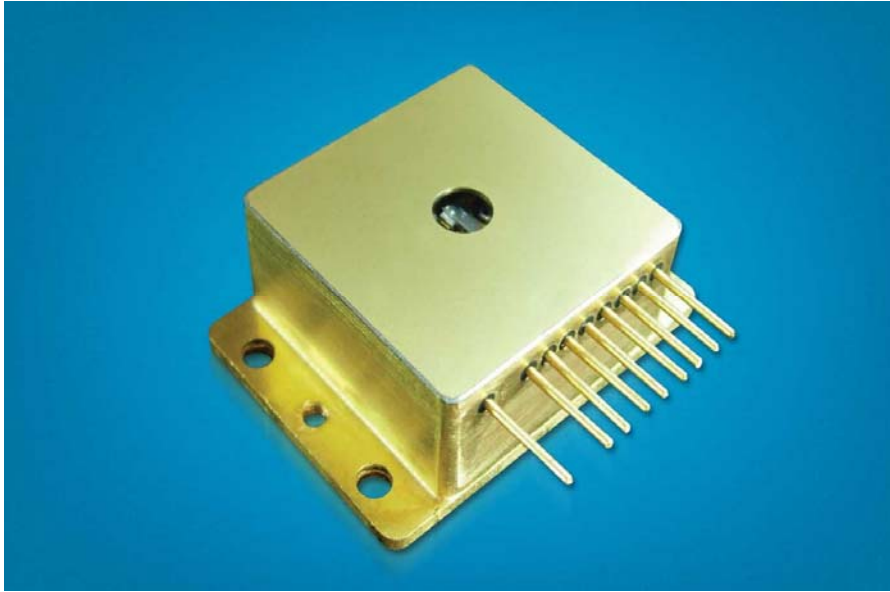

### Key Features:

- ◆ 1W output power
- ◆ 100 $\mu$ m fiber core diameter
- ◆ 660nm~690nm wavelength
- ◆ Window packages

### Applications:

- ◆ Solid-state laser pumping
- ◆ Medical/ophthalmic
- ◆ Materials processing
- ◆ Graphic arts
- ◆ Free-space communication
- ◆ Beacons/illumination

BWT Beijing's High Power Diode Laser Modules are manufactured by adopting specialized fiber-coupling techniques, resulting in volume products with a high efficiency, stability and superior beam quality. Inspecting and burn-in procedures in every aspect come to a result to guarantee each product with the reliability, stability and long lifetime.

Our research staffs are constantly improving and innovating the processing technology in the producing process, based on the professional knowledge and experience accumulated in long-terms. We are also continuously developing new products to meet customers' specific needs.

At BWT Beijing, to provide high quality products with reasonable price is our always goal.

## 660nm~690nm HHL Window Package LD Module

K66S09W-1.00W    K67S09W-1.00W    K68S09W-1.00W    K69S09W-1.00W

Specifications (25°C)		Symbol	Unit	K66S09W-1.00W	K67S09W-1.00W	K68S09W-1.00W	K69S09W-1.00W
Optical data	CW-output power	$P_o$	W	1.0	1.0	1.0	1.0
	Center wavelength	$\lambda_c$	nm	660	670	680	690
	Tolerance of $\lambda$	-	nm	$\pm 5$			
	Spectral width (FWHM)	$\Delta\lambda$	nm	<3			
	Temperature drift of $\lambda$	-	nm/°C	~0.3			
Emitting data	Emitting dimensions	$W \times H$	$\mu\text{m}$	100 × 1			
FWHM beam divergence	Parallel to junction	$\theta_{//}$	degree	10			
	Perpendicular to junction	$\theta_{\perp}$	degree	<40, <10, <2			
Electrical data	Operation current	$I_{op}$	A	1.3			
	Threshold current	$I_{th}$	A	0.3			
	Conversion efficiency <sup>1</sup>	$\eta$	%	37			
	Slope efficiency <sup>2</sup>	$\eta_D$	W/A	1			
	Operation voltage	$V_{op}$	V	2.1			
	Reverse voltage	$V_{re}$	V	2			
PD data	Current	$I_{mo}$	$\mu\text{A}$	200~600			
TEC data	Max. current	$I_t$	A	3.9			
	Max. voltage	$V_t$	V	8.6			
Thermistor data <sup>3</sup>	Thermistor	$R_t$	(K $\Omega$ )/ $\beta$ (25°C)	10 ± 5%/3477			
Other specifications	Operation temperature	$T_{op}$	°C	10~30			
	Storage temperature	$T_{st}$	°C	-20~80			
	Expected lifetime	MTBF	h	>10,000			
	Dimensions	-	mm	~45 × 32 × 16			
	Weight	-	g	~70			
	Lead soldering temperature	$T_{is}$	°C	260(10 sec.)			

1.  $\eta = P_o / (I_{op} V_{op})$ .

2.  $\eta_D = P_o / (I_{op} - I_{th})$ .

3.  $R_T = R_0 \cdot \exp(\beta(1/T - 1/T_0))$ , ( $T_0 = 25^\circ\text{C} = 298\text{K}$ ).

## 660nm~690nm HHL Window Package LD Module

K66S09W-1.00W    K67S09W-1.00W    K68S09W-1.00W    K69S09W-1.00W

### LD Characteristics

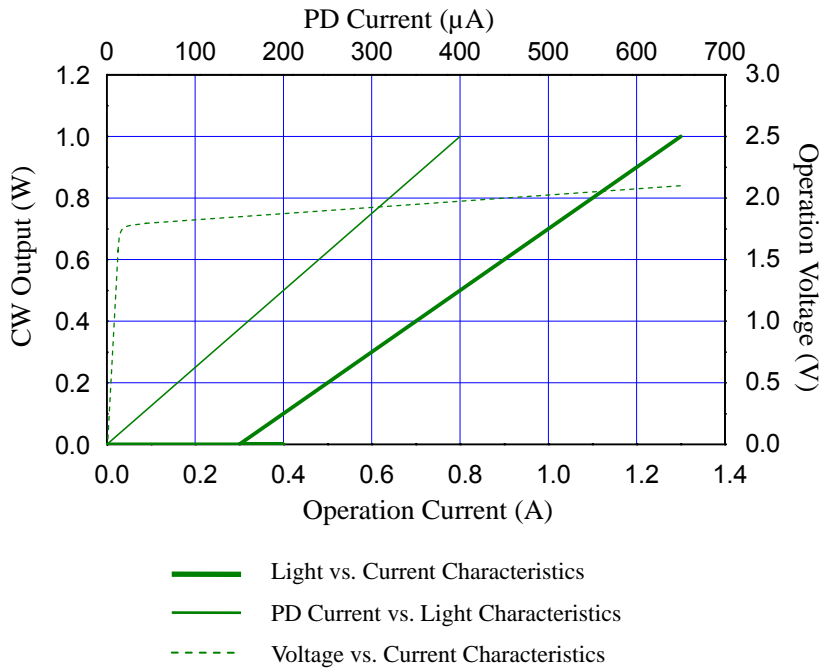

### Typ. spectrum (T=25°C)

Typ. spectrum of 660nm diode laser modules

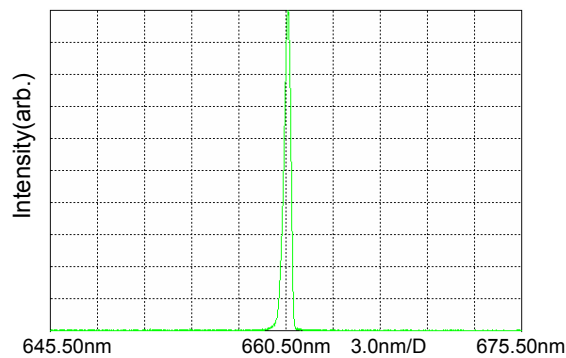

## 660nm~690nm HHL Window Package LD Module

K66S09W-1.00W K67S09W-1.00W K68S09W-1.00W K69S09W-1.00W

### Package Dimensions (mm)

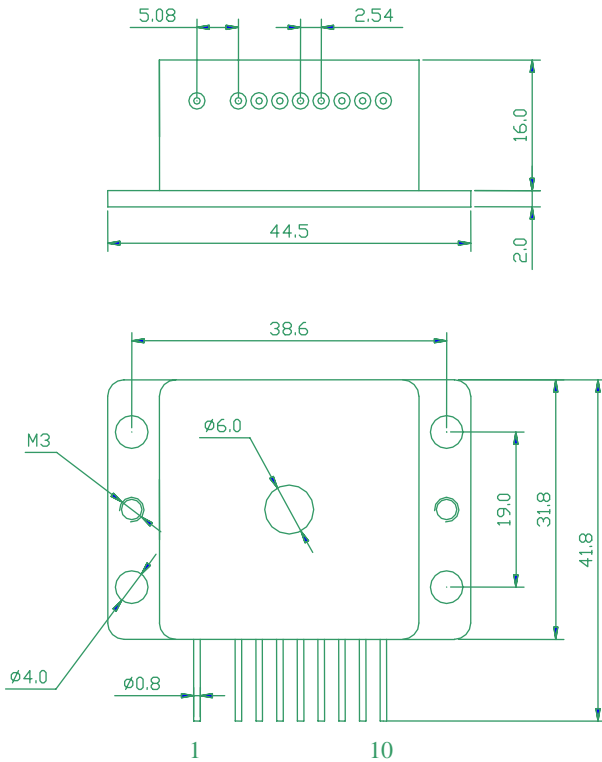

Pin	Function	Pin	Function
1	TEC (-)	6	Thermistor( 2 )
2	None	7	Laser Cathode (-)
3	Case	8	PD (P)
4	Laser Anode (+)	9	PD (N)
5	Thermistor( 1 )	10	TEC (+)

### OPERATING NOTES

- Avoid eye exposure to direct or scattered radiation when the device is in operation.
- ESD precautions must be taken when handling unit.
- Using constant power supplies to guarantee the component works under the limits of its maximum peak optical power.
- The laser diode must be used under the specifications.
- Unit requires a condition to spread the heat as well as possible.
- Keep the fiber end clean before use. Fiber is not allowed to be curved so much. The diameter of curvature should be 300 times greater than fiber diameter.
- Environment temperature is 10°C--30°C.
- Storage temperature is -20°C--80°C, short circuit store.



VISIBLE AND/OR INVISIBLE LASER RADIATION  
AVOID EYE OR SKIN EXPOSURE TO DIRECTOR  
SCATTERED RADIATION  
MAXIMUM OUTPUT IS DEPENDANT UPON AND LESS THAN  
INPUT RADIATION EMITTED WAVELENGTH DEPENDS UPON  
FILTER SETTING CLASS IV LASER PRODUCT



Information and specifications contained herein are deemed to be reliable and accurate. BWT Beijing reserves the right to change, alter or modify the design and specifications of these products at any time with out notice.