

635nm HHL Package Fiber-Coupled LD Module

K63S09F-0.35W

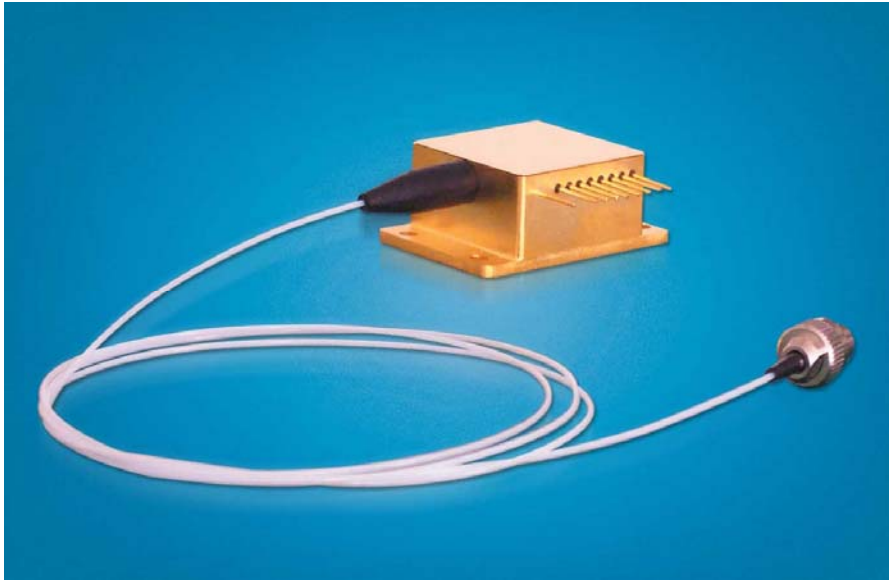

Key Features:

- ◆ 350mW output power
- ◆ 100 μ m or 200 μ m fiber core diameter
- ◆ 0.22NA
- ◆ 635nm wavelength

Applications:

- ◆ Medical use
- ◆ Material processing
- ◆ Biological application

BWT Beijing's High Power Diode Laser Modules are manufactured by adopting specialized fiber-coupling techniques, resulting in volume products with a high efficiency, stability and superior beam quality. The products are achieved by transforming the asymmetric radiation from the laser diode chip into an output fiber with small core diameter by using special micro optics. Inspecting and burn-in procedures in every aspect come to a result to guarantee each product with the reliability, stability and long lifetime.

Our research staffs are constantly improving and innovating the processing technology in the producing process, based on the professional knowledge and experience accumulated in long-terms. We are also continuously developing new products to meet customers' specific needs.

At BWT Beijing, to provide high quality products with reasonable price is our always goal.

635nm HHL Package Fiber-Coupled LD Module

K63S09F-0.35W

Specifications (25°C)		Symbol	Unit	K63S09F-0.35W
Optical data	CW-output power ¹	P_o	mW	350
	Center wavelength	λ_c	nm	635
	Tolerance of λ	-	nm	± 5
	Spectral width (FWHM)	$\Delta\lambda$	nm	<3
	Temperature drift of λ	-	nm/°C	~0.2
Fiber data ²	Fiber core diameter	W_c	μm	100/200
	Numerical aperture	NA	-	0.22
	Fiber connector	-	-	FC, ST, SMA-905
Electrical data	Operation current	I_{op}	A	1.3
	Threshold current	I_{th}	A	0.8
	Conversion efficiency ³	η	%	12
	Slope efficiency ⁴	η_D	W/A	~0.7
	Operation voltage	V_{op}	V	2.2
	Reverse voltage	V_{re}	V	2
PD data	Current	I_{mo}	μA	200~400
TEC data	Max. current	I_t	A	4
	Max. voltage	V_t	V	9.8
Thermistor data ⁵	Thermistor	R_t	(K Ω)/ β (25°C)	10 \pm 5%/3477
Other specifications	Operation temperature	T_{op}	°C	10~30
	Storage temperature	T_{st}	°C	-20~80
	Expected lifetime	MTBF	h	>3000
	Dimensions (fiber and connector not included)	-	mm	~45 \times 32 \times 18
	Weight	-	g	~70
	Lead soldering temperature	T_{is}	°C	260(10 sec.)

1. 2W and 3W output power available for OEM applications. Contact BWT Beijing.

2. Other fibers available for OEM applications. Contact BWT Beijing.

3. $\eta = P_o / (I_{op} V_{op})$.

4. $\eta_D = P_o / (I_{op} - I_{th})$.

5. $R_t = R_0 \cdot \exp(\beta(1/T - 1/T_0))$, ($T_0 = 25^\circ\text{C} = 298\text{K}$).

635nm HHL Package Fiber-Coupled LD Module

K63S09F-0.35W

LD Characteristics

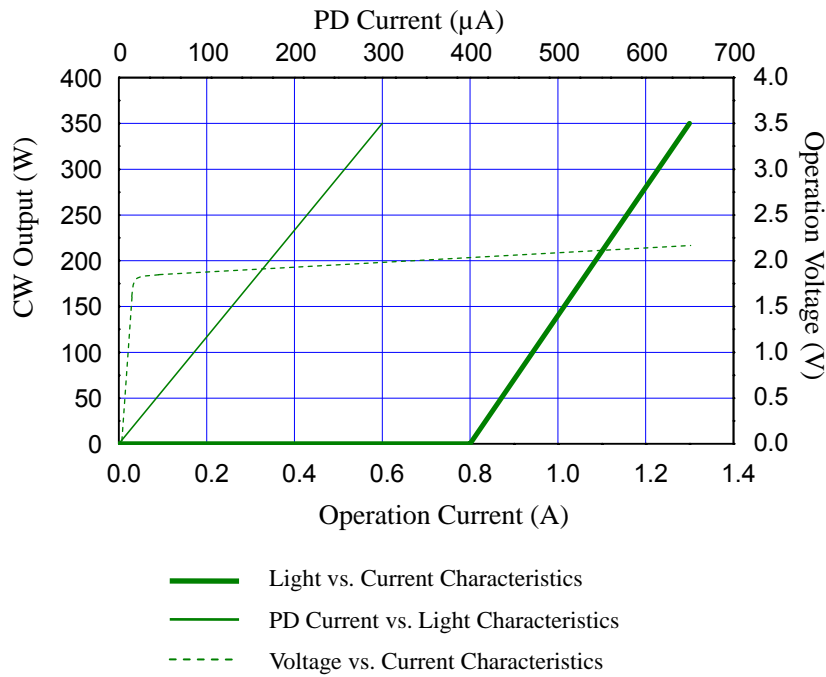

Typ. spectrum (T=25°C)

Typ. spectrum of 635nm diode laser modules

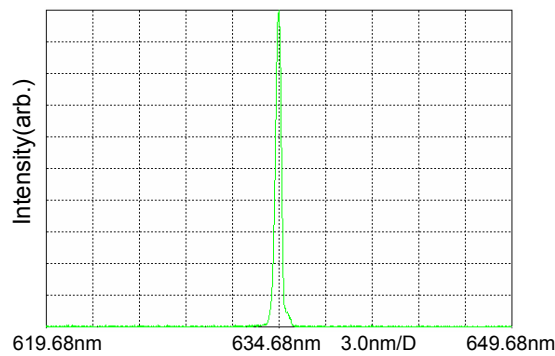

635nm HHL Package Fiber-Coupled LD Module K63S09F-0.35W

Package Dimensions (mm)

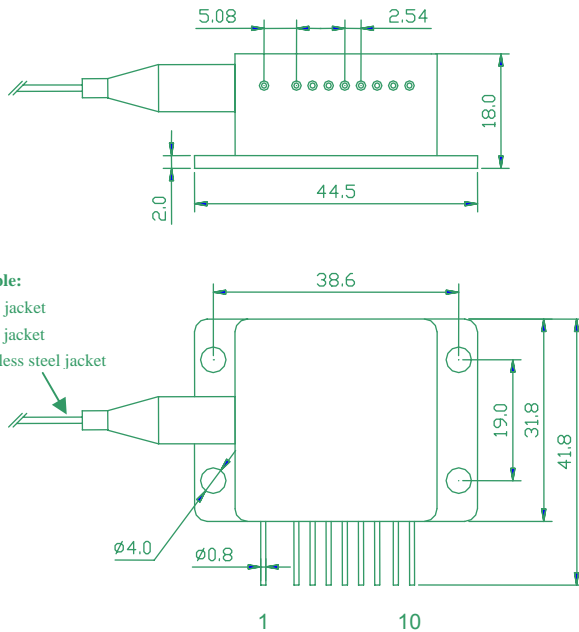

Customer Selectable:

- 900 μ m PVC jacket
- 3.0mm PVC jacket
- 2.1mm stainless steel jacket

Pin	Function	Pin	Function
1	TEC (-)	6	Thermistor(2)
2	-	7	Laser Cathode (-)
3	Case	8	PD (P)
4	Laser Anode (+)	9	PD (N)
5	Thermistor(1)	10	TEC (+)

OPERATING NOTES

- Avoid eye exposure to direct or scattered radiation when the device is in operation.
- ESD precautions must be taken when handling unit.
- Using constant power supplies to guarantee the component works under the limits of its maximum peak optical power.
- The laser diode must be used under the specifications.
- Unit requires a condition to spread the heat as well as possible.
- Keep the fiber end clean before use. Fiber is not allowed to be curved so much. The diameter of curvature should be 300 times greater than fiber diameter.
- Environment temperature is 10°C--30°C.
- Storage temperature is -20°C--80°C, short circuit store.



VISIBLE AND/OR INVISIBLE LASER RADIATION
AVOID EYE OR SKIN EXPOSURE TO DIRECTOR
SCATTERED RADIATION
MAXIMUM OUTPUT IS DEPENDANT UPON AND LESS THAN
INPUT RADIATION EMITTED WAVELENGTH DEPENDS UPON
FILTER SETTING
CLASS IV LASER PRODUCT



Information and specifications contained herein are deemed to be reliable and accurate. BWT Beijing reserves the right to change, alter or modify the design and specifications of these products at any time with out notice.